

# PANDJIRIS, INC

5151 Northrup • St. Louis, MO 63110 • (314) 776-6893

## BETA MODEL 12.5-5 1,250 LB CAPACITY UNIVERSAL COMBINATION WELDING POSITIONER AND COMPANION TAILSTOCK

The **Beta 12.5-5 Positioner** has a motorized variable speed rotation with Forward-Stop-Reverse switch with dynamic braking. The rotation speed is variable from 0.06 to 1.82 RPM with pinned tilt through 90 degrees pinned at 15 degree increments. A 24" square table is standard. The wiring conforms to National Electrical Code Standards and operates on 115 volt, single phase, 60 cycle input power, draws 10 Amps. A field changeable plug-in hand pendant includes "Forward-Stop-Reverse-Weld/Rapid" buttons and a speed adjustment potentiometer on 25' of cable as standard.

Load capacity .....	1,250 lb. 5 inch overhung from face of table, 1,250 lb. 5 inch eccentricity.
Tilt range .....	0 through 90 degrees, pinned.
Swing radius .....	28" @ 90° tilt.
Rotation torque.....	6,250 inch pound.
Rotational motor size .....	1/2 H.P. motor.
Rotation speed .....	Variable from 0.06 to 1.82 RPM.

The **Model TS-12.5 Companion Idler Tailstock** includes a hand tilt through 90 degrees pinned at 15 degree increments. This serves as an ideal turn table with a 1,250 lb. capacity.

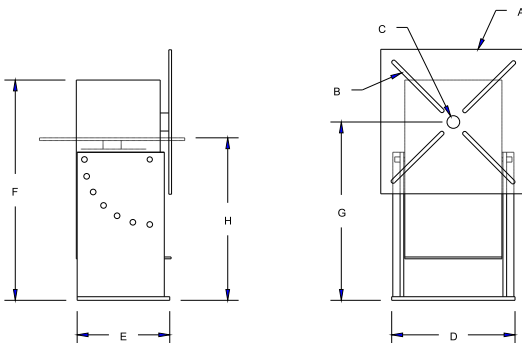

A	Table Size	24" Sq.
B	"T" Slot Quantity	4
	ANSI Std "T" Nut Size	3/8"
C	Pilot Hole	2" x 3/16"
D	Base Width	22-1/2"
E	Base Length	15-5/8"
F	Overall Height	40"
G	Rotation Axis Height	28"
H	Horizontal Table Height	27-1/2"

**Terms:** Pandjiris, Inc. standard terms and conditions apply, f.o.b. Factory, St. Louis, Missouri, or designated ship point.

**Delivery:** Consult factory.  
Approximate shipping weight:  
Beta 12.5-5           550 lbs.  
TS - 12.5-5           300 lbs.

<b>PRICE LIST</b>	
For Bulletin No.	: PC 0991
Effective Date	: May, 2005
Page Number	: A-9

# PANDJIRIS, INC

5151 Northrup • St. Louis, MO 63110 • (314) 776-6893

## POSITIONERS Optional Accessories

Foot switch with compatible plug for Forward/Stop/Reverse (speed potentiometer on hand pendant)

Foot switch, Fast-Slow with compatible plug

Preset digital tachometer with compatible plug reads speed in RPM

Dialweld®, (shows linear speed in IPM for diameter set on diameter selector. Dial diameter to be welded, dial weld speed, table RPM is automatically set to weld diameter at selected welding speed) digital meter with compatible plug reads IPM or CmPM

Tach feedback for precision speed control for Models up to 120-12

25' Extension Cable with compatible plugs for standard pendants and accessories

Model 600 PT Copper Welding Ground

Model 1200 PT Copper Welding Ground

**Terms:** Pandjiris, Inc. standard terms and conditions apply, f.o.b. Factory, St. Louis, Missouri, or designated ship point.

**Delivery:** Consult Factory

### PRICE LIST

For Bulletin No. : PC 0991  
Effective Date : May, 2005  
Page Number : A-10